

P2-17-6-3

PAPER-2

CODE

3

Time : 3 Hours

Maximum Marks : 183

### READ THE INSTRUCTIONS CAREFULLY



#### GENERAL

1. This sealed booklet is your Question Paper. Do not break the seal till you are told to do so.
2. The paper CODE is printed on the right hand top corner of this sheet and the right hand top corner of the back cover of this booklet.
3. Use the Optical Response Sheet (ORS) provided separately for answering the questions.
4. The paper CODE is printed on the left part as well as the right part of the ORS. Ensure that both these codes are identical and same as that on the question paper booklet. If not, contact the invigilator for change of ORS.
5. Blank spaces are provided within this booklet for rough work.
6. Write your name, roll number and sign in the space provided on the back cover of this booklet.
7. After breaking the seal of the booklet at **2:00 pm**, verify that the booklet contains **36** pages and that all the **54** questions along with the options are legible. If not, contact the invigilator for replacement of the booklet.
8. You are allowed to take away the Question Paper at the end of the examination.

#### OPTICAL RESPONSE SHEET

9. The ORS (top sheet) will be provided with an attached Candidate's Sheet (bottom sheet). The Candidate's Sheet is a carbon-less copy of the ORS.
10. Darken the appropriate bubbles on the ORS by applying sufficient pressure. This will leave an impression at the corresponding place on the Candidate's Sheet.
11. The ORS will be collected by the invigilator at the end of the examination.
12. You will be allowed to take away the Candidate's Sheet at the end of the examination.
13. Do not tamper with or mutilate the ORS. **Do not use the ORS for rough work.**
14. Write your name, roll number and code of the examination center, and sign with pen in the space provided for this purpose on the ORS. **Do not write any of these details anywhere else on the ORS.** Darken the appropriate bubble under each digit of your roll number.

#### DARKENING THE BUBBLES ON THE ORS

15. Use a **BLACK BALL POINT PEN** to darken the bubbles on the ORS.
16. Darken the bubble  **COMPLETELY.**
17. The correct way of darkening a bubble is as : 
18. The ORS is machine-gradable. Ensure that the bubbles are darkened in the correct way.
19. Darken the bubbles **ONLY IF** you are sure of the answer. There is **NO WAY** to erase or "un-darken" a darkened bubble.

Please see the last page of this booklet for rest of the instructions.

DO NOT BREAK THE SEALS WITHOUT BEING INSTRUCTED TO DO SO BY THE INVIGILATOR

## PART I : PHYSICS

### SECTION 1 (Maximum Marks: 21)

- This section contains **SEVEN** questions
- Each question has **FOUR** options [A], [B], [C] and [D]. **ONLY ONE** of these four options is correct
- For each question, darken the bubble corresponding to the correct option in the ORS
- For each question, marks will be awarded in one of the following categories:

*Full Marks* : +3 If only the bubble corresponding to the correct option is darkened

*Zero Marks* : 0 If none of the bubbles is darkened

*Negative Marks*: -1 In all other cases

- Q.1 A rocket is launched normal to the surface of the Earth, away from the Sun, along the line joining the Sun and the Earth. The Sun is  $3 \times 10^5$  times heavier than the Earth and is at a distance  $2.5 \times 10^4$  times larger than the radius of the Earth. The escape velocity from Earth's gravitational field is  $v_e = 11.2 \text{ km s}^{-1}$ . The minimum initial velocity ( $v_s$ ) required for the rocket to be able to leave the *Sun-Earth system* is closest to  
(Ignore the rotation and revolution of the Earth and the presence of any other planet)

[A]  $v_s = 22 \text{ km s}^{-1}$

[B]  $v_s = 72 \text{ km s}^{-1}$

[C]  $v_s = 62 \text{ km s}^{-1}$

[D]  $v_s = 42 \text{ km s}^{-1}$

- Q.2 A photoelectric material having work-function  $\phi_0$  is illuminated with light of wavelength  $\lambda$  ( $\lambda < \frac{hc}{\phi_0}$ ). The fastest photoelectron has a de Broglie wavelength  $\lambda_d$ . A change in wavelength of the incident light by  $\Delta\lambda$  results in a change  $\Delta\lambda_d$  in  $\lambda_d$ . Then the ratio  $\Delta\lambda_d/\Delta\lambda$  is proportional to

[A]  $\lambda_d/\lambda$

[B]  $\lambda_d^3/\lambda$

[C]  $\lambda_d^2/\lambda^2$

[D]  $\lambda_d^3/\lambda^2$

Space for rough work

$$\frac{1}{2} m v^2 = \frac{G M m / R}{R}$$

$$v^2 = \frac{2GM}{R} = 11.2$$

$$\sqrt{\frac{3 \times 10^5 \cdot 2GM}{2.5 \times 10^4 R}}$$

$$\sqrt{\frac{2GM}{R}} = 11.2$$

Q.3 A person measures the depth of a well by measuring the time interval between dropping a stone and receiving the sound of impact with the bottom of the well. The error in his measurement of time is  $\delta T = 0.01$  seconds and he measures the depth of the well to be  $L = 20$  meters. Take the acceleration due to gravity  $g = 10 \text{ ms}^{-2}$  and the velocity of sound is  $300 \text{ ms}^{-1}$ . Then the fractional error in the measurement,  $\delta L/L$ , is closest to

- [A] 1%                      [B] 3%                      [C] 0.2%                      [D] 5%

Q.4 A symmetric star shaped conducting wire loop is carrying a steady state current  $I$  as shown in the figure. The distance between the diametrically opposite vertices of the star is  $4a$ . The magnitude of the magnetic field at the center of the loop is

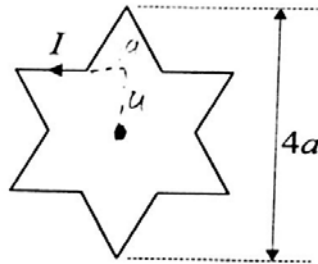

- [A]  $\frac{\mu_0 I}{4\pi a} 6[\sqrt{3} + 1]$                       [B]  $\frac{\mu_0 I}{4\pi a} 3[\sqrt{3} - 1]$   
 [C]  $\frac{\mu_0 I}{4\pi a} 3[2 - \sqrt{3}]$                       [D]  $\frac{\mu_0 I}{4\pi a} 6[\sqrt{3} - 1]$

Space for rough work

$\frac{1}{2} g t^2 = L$   
 0.2  
 $\frac{0.01}{20} \times \frac{5}{700}$   
 0.03  
 0.1 7011

Q.5 Consider an expanding sphere of instantaneous radius  $R$  whose total mass remains constant. The expansion is such that the *instantaneous* density  $\rho$  remains uniform throughout the volume. The rate of fractional change in density  $\left(\frac{1}{\rho} \frac{d\rho}{dt}\right)$  is constant. The velocity  $v$  of any point on the surface of the expanding sphere is proportional to

[A]  $\frac{1}{R}$

[B]  $R^3$

[C]  $R$

[D]  $R^{2/3}$

Q.6 Consider regular polygons with number of sides  $n = 3, 4, 5, \dots$  as shown in the figure. The center of mass of all the polygons is at height  $h$  from the ground. They roll on a horizontal surface about the leading vertex without slipping and sliding as depicted. The maximum increase in height of the locus of the center of mass for each polygon is  $\Delta$ . Then  $\Delta$  depends on  $n$  and  $h$  as

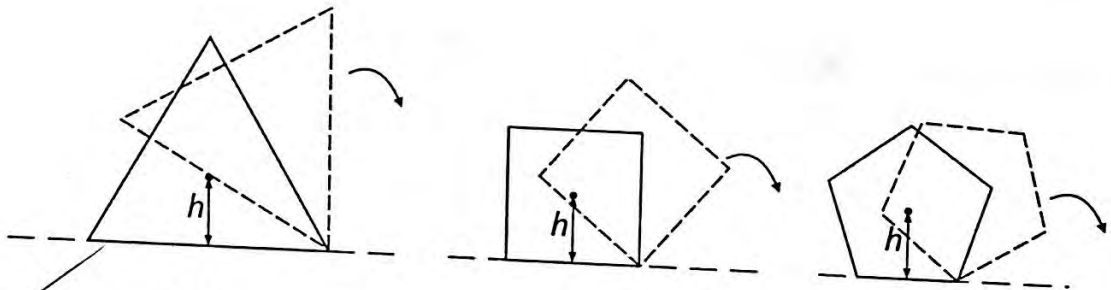

[A]  $\Delta = h \sin^2\left(\frac{\pi}{n}\right)$

[B]  $\Delta = h \tan^2\left(\frac{\pi}{2n}\right)$

[C]  $\Delta = h \left(\frac{1}{\cos\left(\frac{\pi}{n}\right)} - 1\right)$

[D]  $\Delta = h \sin\left(\frac{2\pi}{n}\right)$

Space for rough work

$$\frac{1}{R^3} \cdot \frac{1}{-3R^{-4}}$$

$$\frac{1}{S} \frac{dS}{dt} = k$$

$$\frac{dS}{S} = k dt$$

5/36

$$\frac{-9M dR}{4\pi R^4} = k dt$$

$$dS = \frac{-9M dR}{4\pi R^4}$$

$$S = \frac{M}{V}$$

$$S = \frac{M}{\frac{4}{3}\pi R^3}$$

$$dS = \frac{dM}{\frac{4}{3}\pi R^3}$$

$$\frac{M}{\frac{4}{3}\pi R^3}$$

\*\*3

Q.7 Three vectors  $\vec{P}$ ,  $\vec{Q}$  and  $\vec{R}$  are shown in the figure. Let  $S$  be any point on the vector  $\vec{R}$ . The distance between the points  $P$  and  $S$  is  $b|\vec{R}|$ . The general relation among vectors  $\vec{P}$ ,  $\vec{Q}$  and  $\vec{S}$  is

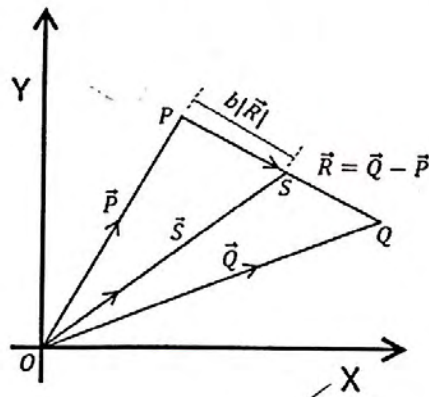

[A]  $\vec{S} = (1 - b^2)\vec{P} + b\vec{Q}$

[B]  $\vec{S} = (1 - b)\vec{P} + b\vec{Q}$

[C]  $\vec{S} = (1 - b)\vec{P} + b^2\vec{Q}$

[D]  $\vec{S} = (b - 1)\vec{P} + b\vec{Q}$

---

Space for rough work

**SECTION 2 (Maximum Marks: 28)**

- This section contains **SEVEN** questions
- Each question has **FOUR** options [A], [B], [C] and [D]. **ONE OR MORE THAN ONE** of these four options is(are) correct
- For each question, darken the bubble(s) corresponding to all the correct option(s) in the ORS
- For each question, marks will be awarded in one of the following categories:

<i>Full Marks</i>	: +4	If only the bubble(s) corresponding to all the correct option(s) is(are) darkened
<i>Partial Marks</i>	: +1	For darkening a bubble corresponding to <b>each correct option</b> , provided <b>NO</b> incorrect option is darkened
<i>Zero Marks</i>	: 0	If none of the bubbles is darkened
<i>Negative Marks</i>	: -2	In all other cases
- For example, if [A], [C] and [D] are all the correct options for a question, darkening all these three will get +4 marks; darkening only [A] and [D] will get +2 marks; and darkening [A] and [B] will get -2 marks, as a wrong option is also darkened

Space for rough work

Q.8 A point charge  $+Q$  is placed just outside an imaginary hemispherical surface of radius  $R$  as shown in the figure. Which of the following statements is/are correct?

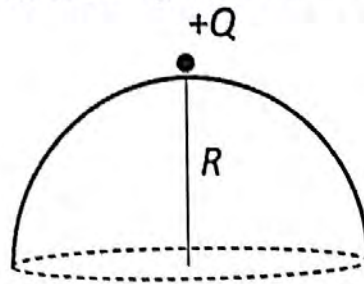

- [A] The electric flux passing through the *curved* surface of the hemisphere is  $-\frac{Q}{2\epsilon_0} \left(1 - \frac{1}{\sqrt{2}}\right)$
- [B] Total flux through the curved and the flat surfaces is  $\frac{Q}{\epsilon_0}$
- [C] The component of the electric field normal to the flat surface is constant over the surface
- [D] The circumference of the flat surface is an equipotential

---

Space for rough work

Q.9 A rigid uniform bar AB of length  $L$  is slipping from its vertical position on a frictionless floor (as shown in the figure). At some instant of time, the angle made by the bar with the vertical is  $\theta$ . Which of the following statements about its motion is/are correct?

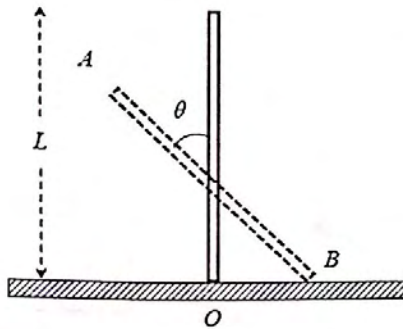

- [A] When the bar makes an angle  $\theta$  with the vertical, the displacement of its midpoint from the initial position is proportional to  $(1 - \cos \theta)$
- [B] Instantaneous torque about the point in contact with the floor is proportional to  $\sin \theta$
- [C] The trajectory of the point A is a parabola
- [D] The midpoint of the bar will fall vertically downward

---

Space for rough work

\*\* 3



Q.10 A uniform magnetic field  $B$  exists in the region between  $x = 0$  and  $x = \frac{3R}{2}$  (region 2 in the figure) pointing normally into the plane of the paper. A particle with charge  $+Q$  and momentum  $p$  directed along  $x$ -axis enters region 2 from region 1 at point  $P_1$  ( $y = -R$ ). Which of the following option(s) is/are correct?

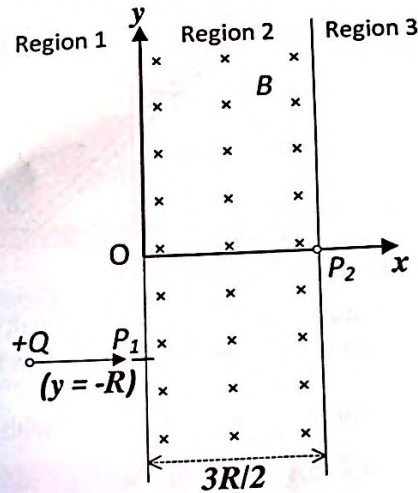

[A] For  $B > \frac{2}{3} \frac{p}{QR}$ , the particle will re-enter region 1

[B] When the particle re-enters region 1 through the longest possible path in region 2, the magnitude of the change in its linear momentum between point  $P_1$  and the farthest point from  $y$ -axis is  $p/\sqrt{2}$

[C] For a fixed  $B$ , particles of same charge  $Q$  and same velocity  $v$ , the distance between the point  $P_1$  and the point of re-entry into region 1 is inversely proportional to the mass of the particle

[D] For  $B = \frac{8}{13} \frac{p}{QR}$ , the particle will enter region 3 through the point  $P_2$  on  $x$ -axis

Space for rough work

$\frac{p}{h}$   $\frac{mv}{h}$

Q.11 A wheel of radius  $R$  and mass  $M$  is placed at the bottom of a fixed step of height  $R$  as shown in the figure. A constant force is continuously applied on the surface of the wheel so that it just climbs the step without slipping. Consider the torque  $\tau$  about an axis normal to the plane of the paper passing through the point  $Q$ . Which of the following options is/are correct?

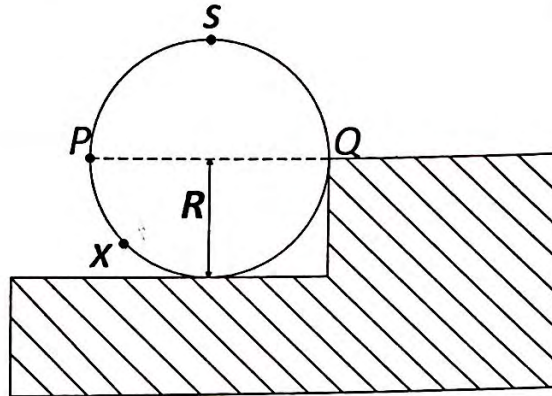

- [A] If the force is applied normal to the circumference at point  $P$  then  $\tau$  is zero
- [B] If the force is applied normal to the circumference at point  $X$  then  $\tau$  is constant
- [C] If the force is applied tangentially at point  $S$  then  $\tau \neq 0$  but the wheel never climbs the step
- [D] If the force is applied at point  $P$  tangentially then  $\tau$  decreases continuously as the wheel climbs

---

Space for rough work

\*\* 3

Q.12 Two coherent monochromatic point sources  $S_1$  and  $S_2$  of wavelength  $\lambda = 600 \text{ nm}$  are placed symmetrically on either side of the center of the circle as shown. The sources are separated by a distance  $d = 1.8 \text{ mm}$ . This arrangement produces interference fringes visible as alternate bright and dark spots on the circumference of the circle. The angular separation between two consecutive bright spots is  $\Delta\theta$ . Which of the following options is/are correct?

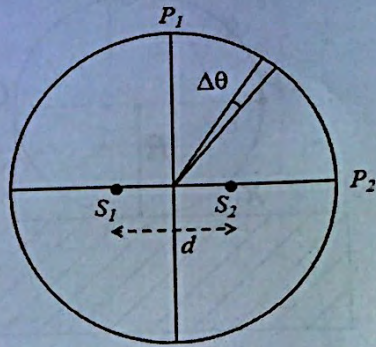

- [A] The total number of fringes produced between  $P_1$  and  $P_2$  in the first quadrant is close to 3000
- [B] A dark spot will be formed at the point  $P_2$
- [C] The angular separation between two consecutive bright spots decreases as we move from  $P_1$  to  $P_2$  along the first quadrant
- [D] At  $P_2$  the order of the fringe will be maximum

---

Space for rough work

- Q.13 A source of constant voltage  $V$  is connected to a resistance  $R$  and two ideal inductors  $L_1$  and  $L_2$  through a switch  $S$  as shown. There is no mutual inductance between the two inductors. The switch  $S$  is initially open. At  $t = 0$ , the switch is closed and current begins to flow. Which of the following options is/are correct?

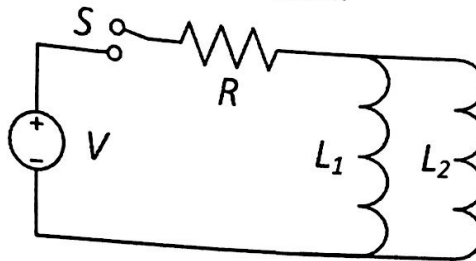

- [A] After a long time, the current through  $L_2$  will be  $\frac{V L_1}{R L_1 + L_2}$
- [B] The ratio of the currents through  $L_1$  and  $L_2$  is fixed at all times ( $t > 0$ )
- [C] After a long time, the current through  $L_1$  will be  $\frac{V L_2}{R L_1 + L_2}$
- [D] At  $t = 0$ , the current through the resistance  $R$  is  $\frac{V}{R}$

- Q.14 The instantaneous voltages at three terminals marked  $X$ ,  $Y$  and  $Z$  are given by

$$V_X = V_0 \sin \omega t,$$

$$V_Y = V_0 \sin \left( \omega t + \frac{2\pi}{3} \right) \text{ and}$$

$$V_Z = V_0 \sin \left( \omega t + \frac{4\pi}{3} \right).$$

An ideal voltmeter is configured to read *rms* value of the potential difference between its terminals. It is connected between points  $X$  and  $Y$  and then between  $Y$  and  $Z$ . The reading(s) of the voltmeter will be

- [A]  $V_{YZ}^{rms} = V_0 \sqrt{\frac{1}{2}}$
- [B] independent of the choice of the two terminals
- [C]  $V_{XY}^{rms} = V_0$
- [D]  $V_{XY}^{rms} = V_0 \sqrt{\frac{3}{2}}$

Space for rough work

**SECTION 3 (Maximum Marks: 12)**

- This section contains **TWO** paragraphs
- Based on each paragraph, there are **TWO** questions
- Each question has **FOUR** options [A], [B], [C], and [D]. **ONLY ONE** of these four options is correct
- For each question, darken the bubble corresponding to the correct option in the ORS
- For each question, marks will be awarded in one of the following categories:

*Full Marks* : +3 If only the bubble corresponding to the correct option is darkened  
*Zero Marks* : 0 In all other cases

**Space for rough work**

### PARAGRAPH 1

Consider a simple  $RC$  circuit as shown in Figure 1.

**Process 1:** In the circuit the switch  $S$  is closed at  $t = 0$  and the capacitor is fully charged to voltage  $V_0$  (i.e., charging continues for time  $T \gg RC$ ). In the process some dissipation ( $E_D$ ) occurs across the resistance  $R$ . The amount of energy finally stored in the fully charged capacitor is  $E_C$ .

**Process 2:** In a different process the voltage is first set to  $\frac{V_0}{3}$  and maintained for a charging time  $T \gg RC$ . Then the voltage is raised to  $\frac{2V_0}{3}$  without discharging the capacitor and again maintained for a time  $T \gg RC$ . The process is repeated one more time by raising the voltage to  $V_0$  and the capacitor is charged to the same final voltage  $V_0$  as in Process 1.

These two processes are depicted in Figure 2.

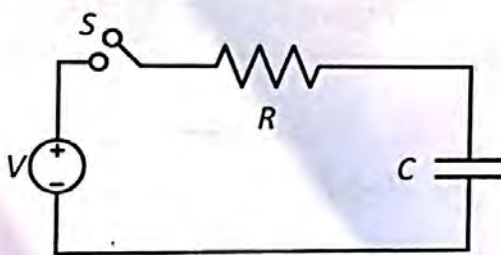

Figure 1

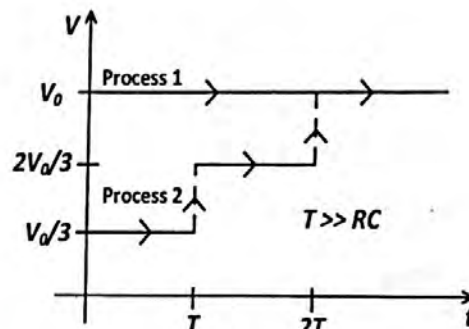

Figure 2

Q.15 In Process 1, the energy stored in the capacitor  $E_C$  and heat dissipated across resistance  $E_D$  are related by:

[A]  $E_C = 2E_D$

[B]  $E_C = E_D \ln 2$

[C]  $E_C = E_D$

[D]  $E_C = \frac{1}{2}E_D$

Q.16 In Process 2, total energy dissipated across the resistance  $E_D$  is:

[A]  $E_D = 3 CV_0^2$

[B]  $E_D = 3 \left(\frac{1}{2} CV_0^2\right)$

[C]  $E_D = \frac{1}{3} \left(\frac{1}{2} CV_0^2\right)$

[D]  $E_D = \frac{1}{2} CV_0^2$

Space for rough work

$\frac{2V_0}{3}$   
 $\frac{V_0}{3}$

PARAGRAPH 2

One twirls a circular ring (of mass  $M$  and radius  $R$ ) near the tip of one's finger as shown in Figure 1. In the process the finger never loses contact with the inner rim of the ring. The finger traces out the surface of a cone, shown by the dotted line. The radius of the path traced out by the point where the ring and the finger is in contact is  $r$ . The finger rotates with an angular velocity  $\omega_0$ . The rotating ring *rolls without slipping* on the outside of a smaller circle described by the point where the ring and the finger is in contact (Figure 2). The coefficient of friction between the ring and the finger is  $\mu$  and the acceleration due to gravity is  $g$ .

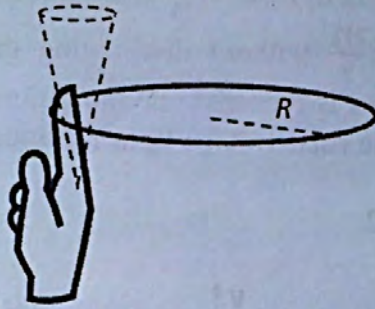

Figure 1

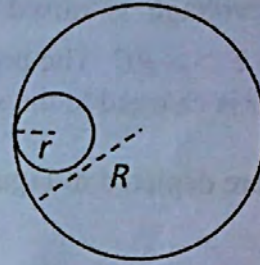

Figure 2

Q.17 The total kinetic energy of the ring is

[A]  $M\omega_0^2 R^2$

[B]  $M\omega_0^2 (R - r)^2$

[C]  $\frac{3}{2} M\omega_0^2 (R - r)^2$

[D]  $\frac{1}{2} M\omega_0^2 (R - r)^2$

Q.18 The minimum value of  $\omega_0$  below which the ring will drop down is

[A]  $\sqrt{\frac{3g}{2\mu(R-r)}}$

[B]  $\sqrt{\frac{g}{2\mu(R-r)}}$

[C]  $\sqrt{\frac{2g}{\mu(R-r)}}$

[D]  $\sqrt{\frac{g}{\mu(R-r)}}$

END OF PART I : PHYSICS

Space for rough work

## PART II : CHEMISTRY

### SECTION 1 (Maximum Marks: 21)

- This section contains SEVEN questions
- Each question has FOUR options [A], [B], [C] and [D]. ONLY ONE of these four options is correct
- For each question, darken the bubble corresponding to the correct option in the ORS
- For each question, marks will be awarded in one of the following categories:

**Full Marks** : +3 If only the bubble corresponding to the correct option is darkened  
**Zero Marks** : 0 If none of the bubbles is darkened  
**Negative Marks**: -1 In all other cases

Q.19 Pure water freezes at 273 K and 1 bar. The addition of 34.5 g of ethanol to 500 g of water changes the freezing point of the solution. Use the freezing point depression constant of water as  $2 \text{ K kg mol}^{-1}$ . The figures shown below represent plots of vapour pressure (V.P.) versus temperature (T). [molecular weight of ethanol is  $46 \text{ g mol}^{-1}$ ]  
 Among the following, the option representing change in the freezing point is

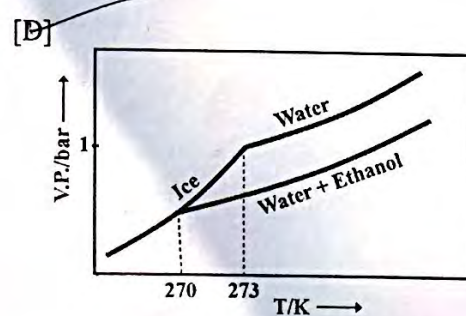
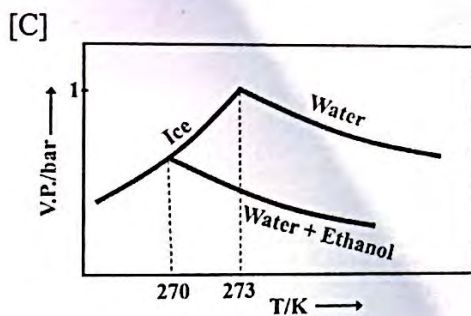
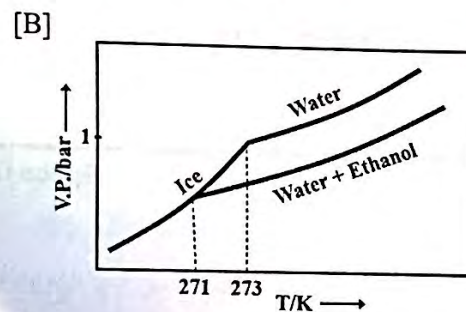
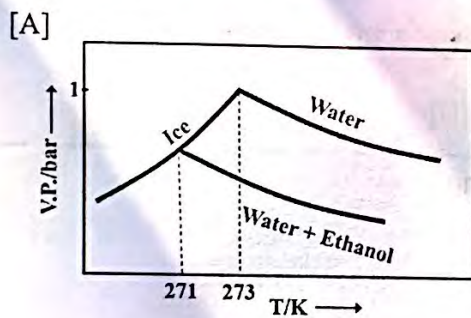

Space for rough work

$$\begin{array}{r}
 25 \times 34.5 \\
 \hline
 46 \\
 23
 \end{array}$$

$$\begin{array}{r}
 69.03 \\
 \hline
 231
 \end{array}$$



Q.20 The standard state Gibbs free energies of formation of C(graphite) and C(diamond) at  $T = 298 \text{ K}$  are

$$\Delta_f G^\circ[\text{C}(\text{graphite})] = 0 \text{ kJ mol}^{-1}$$

$$\Delta_f G^\circ[\text{C}(\text{diamond})] = 2.9 \text{ kJ mol}^{-1}$$

The standard state means that the pressure should be 1 bar, and substance should be pure at a given temperature. The conversion of graphite [C(graphite)] to diamond [C(diamond)] reduces its volume by  $2 \times 10^{-6} \text{ m}^3 \text{ mol}^{-1}$ . If C(graphite) is converted to C(diamond) isothermally at  $T = 298 \text{ K}$ , the pressure at which C(graphite) is in equilibrium with C(diamond), is

[Useful information:  $1 \text{ J} = 1 \text{ kg m}^2 \text{ s}^{-2}$ ;  $1 \text{ Pa} = 1 \text{ kg m}^{-1} \text{ s}^{-2}$ ;  $1 \text{ bar} = 10^5 \text{ Pa}$ ]

- [A] 14501 bar       [B] 1450 bar      [C] 58001 bar      [D] 29001 bar

Q.21 For the following cell,

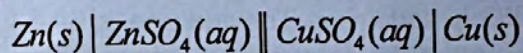

when the concentration of  $\text{Zn}^{2+}$  is 10 times the concentration of  $\text{Cu}^{2+}$ , the expression for  $\Delta G$  (in  $\text{J mol}^{-1}$ ) is

[F is Faraday constant; R is gas constant; T is temperature;  $E^\circ(\text{cell}) = 1.1 \text{ V}$ ]

[A]  $2.303RT + 1.1F$

[B]  $2.303RT - 2.2F$

[C]  $-2.2F$

[D]  $1.1F$

---

Space for rough work

Q.22 The major product of the following reaction is

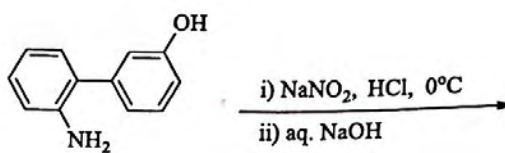

[A]

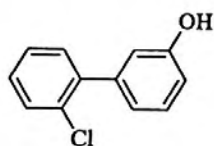

[B]

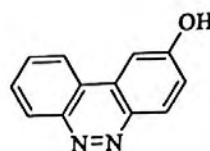

[C]

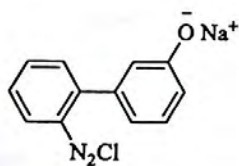

[D]

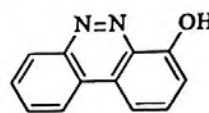

Q.23 The order of basicity among the following compounds is

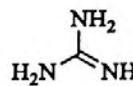
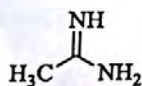

I

II

III

IV

[A] ~~II > I > IV > III~~

[B] IV > I > II > III

[C] IV > II > III > I

[D] I > IV > III > II

Space for rough work

Q.24 Which of the following combination will produce  $H_2$  gas?

- [A] Au metal and  $NaCN(aq)$  in the presence of air
- [B] Fe metal and conc.  $HNO_3$
- [C] Zn metal and  $NaOH(aq)$
- [D] Cu metal and conc.  $HNO_3$

Q.25 The order of the oxidation state of the phosphorus atom in  $H_3PO_2$ ,  $H_3PO_4$ ,  $H_3PO_3$ , and  $H_4P_2O_6$  is

- [A]  $H_3PO_4 > H_4P_2O_6 > H_3PO_3 > H_3PO_2$
- [B]  $H_3PO_4 > H_3PO_2 > H_3PO_3 > H_4P_2O_6$
- [C]  $H_3PO_3 > H_3PO_2 > H_3PO_4 > H_4P_2O_6$
- [D]  $H_3PO_2 > H_3PO_3 > H_4P_2O_6 > H_3PO_4$

---

Space for rough work

**SECTION 2 (Maximum Marks: 28)**

- This section contains **SEVEN** questions
- Each question has **FOUR** options [A], [B], [C] and [D]. **ONE OR MORE THAN ONE** of these four options is(are) correct
- For each question, darken the bubble(s) corresponding to all the correct option(s) in the ORS
- For each question, marks will be awarded in one of the following categories:

<i>Full Marks</i>	: +4	If only the bubble(s) corresponding to all the correct option(s) is(are) darkened
<i>Partial Marks</i>	: +1	For darkening a bubble corresponding to <b>each correct option</b> , provided <b>NO</b> incorrect option is darkened
<i>Zero Marks</i>	: 0	If none of the bubbles is darkened
<i>Negative Marks</i>	: -2	In all other cases
- For example, if [A], [C] and [D] are all the correct options for a question, darkening all these three will get +4 marks; darkening only [A] and [D] will get +2 marks; and darkening [A] and [B] will get -2 marks, as a wrong option is also darkened

Q.26 For a reaction taking place in a container in equilibrium with its surroundings, the effect of temperature on its equilibrium constant  $K$  in terms of change in entropy is described by

- [A] With increase in temperature, the value of  $K$  for exothermic reaction decreases because the entropy change of the system is positive
- [B] With increase in temperature, the value of  $K$  for endothermic reaction increases because the entropy change of the system is negative
- [C] With increase in temperature, the value of  $K$  for exothermic reaction decreases because favourable change in entropy of the surroundings decreases
- [D] With increase in temperature, the value of  $K$  for endothermic reaction increases because unfavourable change in entropy of the surroundings decreases

---

Space for rough work

Q.27 Among the following, the correct statement(s) is(are)

- [A]  $\text{Al}(\text{CH}_3)_3$  has the three-centre two-electron bonds in its dimeric structure
- [B]  $\text{AlCl}_3$  has the three-centre two-electron bonds in its dimeric structure
- [C]  $\text{BH}_3$  has the three-centre two-electron bonds in its dimeric structure
- [D] The Lewis acidity of  $\text{BCl}_3$  is greater than that of  $\text{AlCl}_3$

Q.28 The correct statement(s) about surface properties is(are)

- [A] Adsorption is accompanied by decrease in enthalpy and decrease in entropy of the system
- [B] The critical temperatures of ethane and nitrogen are 563 K and 126 K, respectively. The adsorption of ethane will be more than that of nitrogen on same amount of activated charcoal at a given temperature
- [C] Cloud is an emulsion type of colloid in which liquid is dispersed phase and gas is dispersion medium
- [D] Brownian motion of colloidal particles does not depend on the size of the particles but depends on viscosity of the solution

Q.29 For the following compounds, the correct statement(s) with respect to nucleophilic substitution reactions is(are)

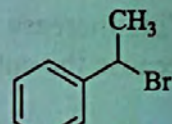
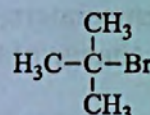
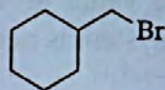
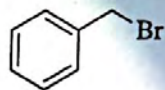

- [A] ~~I and III~~ follow  $\text{S}_{\text{N}}1$  mechanism
- [B] ~~I and II~~ follow  $\text{S}_{\text{N}}2$  mechanism
- [C] Compound IV undergoes inversion of configuration
- [D] The order of reactivity for I, III and IV is:  $\text{IV} > \text{I} > \text{III}$

---

Space for rough work

Q.30 In a bimolecular reaction, the steric factor P was experimentally determined to be 4.5. The correct option(s) among the following is(are)

- [A] Since  $P = 4.5$ , the reaction will not proceed unless an effective catalyst is used
- [B] The activation energy of the reaction is unaffected by the value of the steric factor
- [C] Experimentally determined value of frequency factor is higher than that predicted by Arrhenius equation
- [D] The value of frequency factor predicted by Arrhenius equation is higher than that determined experimentally

Q.31 The option(s) with only amphoteric oxides is(are)

- [A]  $\text{Cr}_2\text{O}_3, \text{BeO}, \text{SnO}, \text{SnO}_2$
- [B]  $\text{ZnO}, \text{Al}_2\text{O}_3, \text{PbO}, \text{PbO}_2$
- [C]  $\text{Cr}_2\text{O}_3, \text{CrO}, \text{SnO}, \text{PbO}$
- [D]  $\text{NO}, \text{B}_2\text{O}_3, \text{PbO}, \text{SnO}_2$

Q.32 Compounds P and R upon ozonolysis produce Q and S, respectively. The molecular formula of Q and S is  $\text{C}_8\text{H}_8\text{O}$ . Q undergoes Cannizzaro reaction but not haloform reaction, whereas S undergoes haloform reaction but not Cannizzaro reaction.

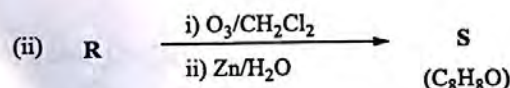
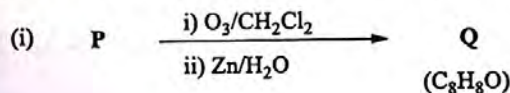

The option(s) with suitable combination of P and R, respectively, is(are)

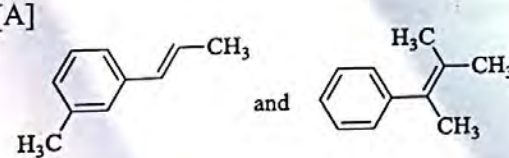
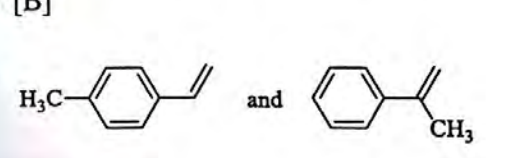
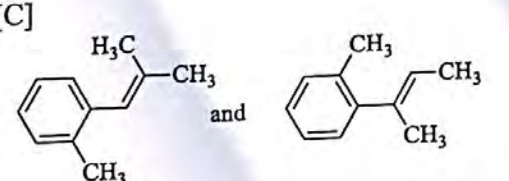
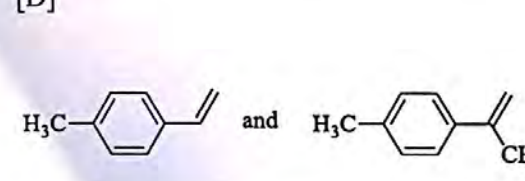
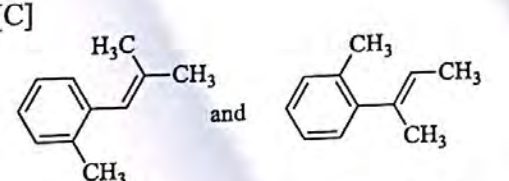
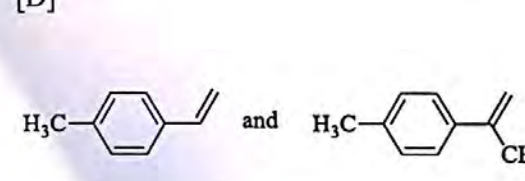
- [A]  and 
- [B]  and 
- [C] 
- [D] 

Space for rough work

**SECTION 3 (Maximum Marks: 12)**

- This section contains **TWO** paragraphs
- Based on each paragraph, there are **TWO** questions
- Each question has **FOUR** options [A], [B], [C], and [D]. **ONLY ONE** of these four options is correct
- For each question, darken the bubble corresponding to the correct option in the ORS
- For each question, marks will be awarded in one of the following categories:

*Full Marks* : +3 If only the bubble corresponding to the correct option is darkened  
*Zero Marks* : 0 In all other cases

**PARAGRAPH 1**

Upon heating  $\text{KClO}_3$  in the presence of catalytic amount of  $\text{MnO}_2$ , a gas **W** is formed. Excess amount of **W** reacts with white phosphorus to give **X**. The reaction of **X** with pure  $\text{HNO}_3$  gives **Y** and **Z**.

Q.33 **Y** and **Z** are, respectively

[A]  $\text{N}_2\text{O}_3$  and  $\text{H}_3\text{PO}_4$

[B]  $\text{N}_2\text{O}_5$  and  $\text{HPO}_3$

[C]  $\text{N}_2\text{O}_4$  and  $\text{HPO}_3$

[D]  $\text{N}_2\text{O}_4$  and  $\text{H}_3\text{PO}_3$

Q.34 **W** and **X** are, respectively

[A]  $\text{O}_2$  and  $\text{P}_4\text{O}_{10}$

[B]  $\text{O}_2$  and  $\text{P}_4\text{O}_6$

[C]  $\text{O}_3$  and  $\text{P}_4\text{O}_6$

[D]  $\text{O}_3$  and  $\text{P}_4\text{O}_{10}$

---

Space for rough work

PARAGRAPH 2

The reaction of compound **P** with  $\text{CH}_3\text{MgBr}$  (excess) in  $(\text{C}_2\text{H}_5)_2\text{O}$  followed by addition of  $\text{H}_2\text{O}$  gives **Q**. The compound **Q** on treatment with  $\text{H}_2\text{SO}_4$  at  $0^\circ\text{C}$  gives **R**. The reaction of **R** with  $\text{CH}_3\text{COCl}$  in the presence of anhydrous  $\text{AlCl}_3$  in  $\text{CH}_2\text{Cl}_2$  followed by treatment with  $\text{H}_2\text{O}$  produces compound **S**. [Et in compound **P** is ethyl group]

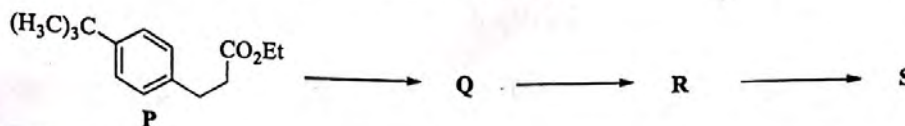

Q.35 The reactions, **Q** to **R** and **R** to **S**, are

- [A] Dehydration and Friedel-Crafts acylation
- [B] Friedel-Crafts alkylation, dehydration and Friedel-Crafts acylation
- [C] Aromatic sulfonation and Friedel-Crafts acylation
- [D] Friedel-Crafts alkylation and Friedel-Crafts acylation

Q.36 The product **S** is

[A] ✓

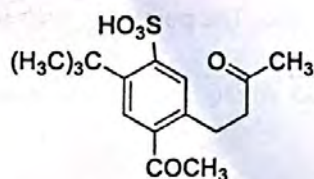

[B]

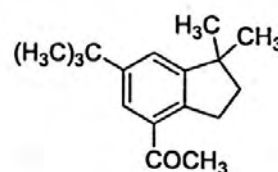

[C]

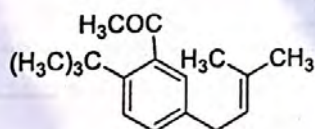

[D]

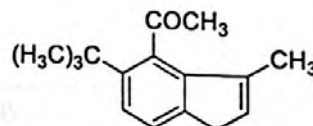

END OF PART II : CHEMISTRY

Space for rough work



## PART III : MATHEMATICS

### SECTION 1 (Maximum Marks: 21)

- This section contains SEVEN questions
- Each question has FOUR options [A], [B], [C] and [D]. ONLY ONE of these four options is correct
- For each question, darken the bubble corresponding to the correct option in the ORS
- For each question, marks will be awarded in one of the following categories:

*Full Marks* : +3 If only the bubble corresponding to the correct option is darkened  
*Zero Marks* : 0 If none of the bubbles is darkened  
*Negative Marks*: -1 In all other cases

Q.37 The equation of the plane passing through the point (1, 1, 1) and perpendicular to the planes  $2x + y - 2z = 5$  and  $3x - 6y - 2z = 7$ , is

[A]  $14x + 2y + 15z = 31$

[B]  $14x - 2y + 15z = 27$

[C]  $14x + 2y - 15z = 1$

[D]  $-14x + 2y + 15z = 3$

Q.38 Let  $O$  be the origin and let  $PQR$  be an arbitrary triangle. The point  $S$  is such that

$$\overrightarrow{OP} \cdot \overrightarrow{OQ} + \overrightarrow{OR} \cdot \overrightarrow{OS} = \overrightarrow{OR} \cdot \overrightarrow{OP} + \overrightarrow{OQ} \cdot \overrightarrow{OS} = \overrightarrow{OQ} \cdot \overrightarrow{OR} + \overrightarrow{OP} \cdot \overrightarrow{OS}$$

Then the triangle  $PQR$  has  $S$  as its

[A] centroid

[B] circumcentre

[C] orthocenter

[D] incentre

---

Space for rough work

Q.39 Let  $S = \{1, 2, 3, \dots, 9\}$ . For  $k = 1, 2, \dots, 5$ , let  $N_k$  be the number of subsets of  $S$ , each containing five elements out of which exactly  $k$  are odd. Then  $N_1 + N_2 + N_3 + N_4 + N_5 =$

- [A] 252                      [B] 125                      [C] 210                      [D] 126

Q.40 Three randomly chosen nonnegative integers  $x, y$  and  $z$  are found to satisfy the equation  $x + y + z = 10$ . Then the probability that  $z$  is even, is

- [A]  $\frac{1}{2}$                       [B]  $\frac{6}{11}$                       [C]  $\frac{36}{55}$                       [D]  $\frac{5}{11}$

Q.41 How many  $3 \times 3$  matrices  $M$  with entries from  $\{0, 1, 2\}$  are there, for which the sum of the diagonal entries of  $M^T M$  is 5?

- [A] 135                      [B] 126                      [C] 162                      [D] 198

Space for rough work

1, 2, 3, 4, 5, 6, 7, 8, 9

$${}^4C_4 {}^5C_1 + {}^4C_3 {}^5C_2 + {}^4C_2 {}^5C_3 + {}^4C_1 {}^5C_4 + \frac{{}^4C_0 {}^5C_5}{2}$$

$$5 + 4 \times \frac{5 \times 4^2}{2} + \frac{4 \times 3}{2} \times \frac{5 \times 4^2}{2} + 4 \times 5 + 1$$

$$5 + 40 + 60 + 20 + 1$$

$$126$$

$$\frac{1}{2} \times 1 + \frac{1}{2} \times \frac{1}{3}$$

$$\frac{126}{.}$$

$$\frac{1}{2} + \frac{1}{6}$$

$$\frac{3+4}{6} = \frac{7}{6}$$

$$6 \times 3$$

Q.42 If  $y = y(x)$  satisfies the differential equation

$$8\sqrt{x} \left( \sqrt{9 + \sqrt{x}} \right) dy = \left( \sqrt{4 + \sqrt{9 + \sqrt{x}}} \right)^{-1} dx, \quad x > 0$$

and  $y(0) = \sqrt{7}$ , then  $y(256) =$

[A] 16

[B] 9

[C] 3

[D] 80

Q.43 If  $f: \mathbb{R} \rightarrow \mathbb{R}$  is a twice differentiable function such that  $f''(x) > 0$  for all  $x \in \mathbb{R}$ , and  $f\left(\frac{1}{2}\right) = \frac{1}{2}$ ,  $f(1) = 1$ , then

[A]  $f'(1) > 1$

[B]  $f'(1) \leq 0$

[C]  $0 < f'(1) \leq \frac{1}{2}$

[D]  $\frac{1}{2} < f'(1) \leq 1$

Space for rough work

$$\frac{dy}{dx} = \frac{1}{8\sqrt{x} (\sqrt{9 + \sqrt{x}}) \sqrt{4 + \sqrt{9 + \sqrt{x}}}}$$

**SECTION 2 (Maximum Marks: 28)**

- This section contains **SEVEN** questions
- Each question has **FOUR** options [A], [B], [C] and [D]. **ONE OR MORE THAN ONE** of these four options is(are) correct
- For each question, darken the bubble(s) corresponding to all the correct option(s) in the ORS
- For each question, marks will be awarded in one of the following categories:

<i>Full Marks</i>	: +4	If only the bubble(s) corresponding to all the correct option(s) is(are) darkened
<i>Partial Marks</i>	: +1	For darkening a bubble corresponding to <b>each correct option</b> , provided <b>NO</b> incorrect option is darkened
<i>Zero Marks</i>	: 0	If none of the bubbles is darkened
<i>Negative Marks</i>	: -2	In all other cases

- For example, if [A], [C] and [D] are all the correct options for a question, darkening all these three will get +4 marks; darkening only [A] and [D] will get +2 marks; and darkening [A] and [B] will get -2 marks, as a wrong option is also darkened

Q.44 Let  $\alpha$  and  $\beta$  be nonzero real numbers such that  $2(\cos \beta - \cos \alpha) + \cos \alpha \cos \beta = 1$ . Then which of the following is/are true?

[A]  $\sqrt{3} \tan\left(\frac{\alpha}{2}\right) - \tan\left(\frac{\beta}{2}\right) = 0$

[B]  $\tan\left(\frac{\alpha}{2}\right) + \sqrt{3} \tan\left(\frac{\beta}{2}\right) = 0$

[C]  $\sqrt{3} \tan\left(\frac{\alpha}{2}\right) + \tan\left(\frac{\beta}{2}\right) = 0$

[D]  $\tan\left(\frac{\alpha}{2}\right) - \sqrt{3} \tan\left(\frac{\beta}{2}\right) = 0$

Q.45 If  $g(x) = \int_{\sin x}^{\sin(2x)} \sin^{-1}(t) dt$ , then

[A]  $g'\left(\frac{\pi}{2}\right) = 2\pi$

[B]  $g'\left(-\frac{\pi}{2}\right) = 2\pi$

[C]  $g'\left(-\frac{\pi}{2}\right) = -2\pi$

[D]  $g'\left(\frac{\pi}{2}\right) = -2\pi$

---

Space for rough work

Q.46 If  $f(x) = \begin{vmatrix} \cos(2x) & \cos(2x) & \sin(2x) \\ -\cos x & \cos x & -\sin x \\ \sin x & \sin x & \cos x \end{vmatrix}$ , then

- [A]  $f(x)$  attains its maximum at  $x = 0$
- [B]  $f'(x) = 0$  at exactly three points in  $(-\pi, \pi)$
- [C]  $f'(x) = 0$  at more than three points in  $(-\pi, \pi)$
- [D]  $f(x)$  attains its minimum at  $x = 0$

Q.47 Let  $f(x) = \frac{1-x(1+|1-x|)}{|1-x|} \cos\left(\frac{1}{1-x}\right)$  for  $x \neq 1$ . Then

- [A]  $\lim_{x \rightarrow 1^-} f(x) = 0$
- [B]  $\lim_{x \rightarrow 1^-} f(x)$  does not exist
- [C]  $\lim_{x \rightarrow 1^+} f(x) = 0$
- [D]  $\lim_{x \rightarrow 1^+} f(x)$  does not exist

Q.48 If the line  $x = \alpha$  divides the area of region  $R = \{(x, y) \in \mathbb{R}^2 : x^3 \leq y \leq x, 0 \leq x \leq 1\}$  into two equal parts, then

- [A]  $\frac{1}{2} < \alpha < 1$
- [B]  $2\alpha^4 - 4\alpha^2 + 1 = 0$
- [C]  $0 < \alpha \leq \frac{1}{2}$
- [D]  $\alpha^4 + 4\alpha^2 - 1 = 0$

---

Space for rough work

Q.49 If  $f: \mathbb{R} \rightarrow \mathbb{R}$  is a differentiable function such that  $f'(x) > 2f(x)$  for all  $x \in \mathbb{R}$ , and  $f(0) = 1$ , then

[A]  $f(x) > e^{2x}$  in  $(0, \infty)$

[B]  $f(x)$  is increasing in  $(0, \infty)$

[C]  $f'(x) < e^{2x}$  in  $(0, \infty)$

[D]  $f(x)$  is decreasing in  $(0, \infty)$

Q.50 If  $I = \sum_{k=1}^{98} \int_k^{k+1} \frac{k+1}{x(x+1)} dx$ , then

[A]  $I > \log_e 99$

[B]  $I < \log_e 99$

[C]  $I < \frac{49}{50}$

[D]  $I > \frac{49}{50}$

---

Space for rough work

**SECTION 3 (Maximum Marks: 12)**

- This section contains **TWO** paragraphs
- Based on each paragraph, there are **TWO** questions
- Each question has **FOUR** options [A], [B], [C], and [D]. **ONLY ONE** of these four options is correct
- For each question, darken the bubble corresponding to the correct option in the ORS
- For each question, marks will be awarded in one of the following categories:

*Full Marks* : +3 If only the bubble corresponding to the correct option is darkened  
*Zero Marks* : 0 In all other cases

**PARAGRAPH 1**

Let  $O$  be the origin, and  $\vec{OX}$ ,  $\vec{OY}$ ,  $\vec{OZ}$  be three unit vectors in the directions of the sides  $\vec{QR}$ ,  $\vec{RP}$ ,  $\vec{PQ}$ , respectively, of a triangle  $PQR$ .

Q.51  $|\vec{OX} \times \vec{OY}| =$

- [A]  $\sin 2R$       [B]  $\sin(P + R)$       [C]  $\sin(P + Q)$       [D]  $\sin(Q + R)$

Q.52 If the triangle  $PQR$  varies, then the minimum value of  $\cos(P + Q) + \cos(Q + R) + \cos(R + P)$

is

- [A]  $\frac{5}{3}$       [B]  $-\frac{5}{3}$       [C]  $\frac{3}{2}$       [D]  $-\frac{3}{2}$

Space for rough work

PARAGRAPH 2

Let  $p, q$  be integers and let  $\alpha, \beta$  be the roots of the equation,  $x^2 - x - 1 = 0$ , where  $\alpha \neq \beta$ . For  $n = 0, 1, 2, \dots$ , let  $a_n = p\alpha^n + q\beta^n$ .

**FACT:** If  $a$  and  $b$  are rational numbers and  $a + b\sqrt{5} = 0$ , then  $a = 0 = b$ .

Q.53  $a_{12} =$

[A]  $2a_{11} + a_{10}$

~~[B]  $a_{11} + a_{10}$~~

[C]  $a_{11} + 2a_{10}$

[D]  $a_{11} - a_{10}$

Q.54 If  $a_4 = 28$ , then  $p + 2q =$

[A] 12

[B] 7

[C] 14

[D] 21

END OF THE QUESTION PAPER

Space for rough work

$a_0 = p + q$

$a_1 = p \left( \frac{1+\sqrt{5}}{2} \right) + q \left( \frac{1-\sqrt{5}}{2} \right)$

$a_4 = a_3 + 2a_2$

$a_4 = a_3 + (a_1 + 2a_0)$

$a_{12} = a_{11} + a_{10}$

$= a_{10} + a_9 + a_9 + a_8$



$x^2 = x + 1$

$\frac{1 \pm \sqrt{5} + 1}{2} = \alpha, \beta$

$\frac{1 + \sqrt{5}}{2}$

$a_4 = a_3 + a_2$

$= a_2 + a_1 + a_1 + a_0$

$= a_1 + a_0 + a_1 + a_0$

$3a_1 + 2a_0$

\*\*3



### QUESTION PAPER FORMAT AND MARKING SCHEME

20. The question paper has three parts: Physics, Chemistry and Mathematics.

21. Each part has three sections as detailed in the following table:

Section	Question Type	Number of Questions	Category-wise Marks for Each Question				Maximum Marks of the Section
			Full Marks	Partial Marks	Zero Marks	Negative Marks	
1	Single Correct Option	7	+3 If only the bubble corresponding to the correct option is darkened	—	0 If none of the bubbles is darkened	-1 In all other cases	21
2	One or more correct option(s)	7	+4 If only the bubble(s) corresponding to all the correct option(s) is(are) darkened	+1 For darkening a bubble corresponding to each correct option, provided NO incorrect option is darkened	0 If none of the bubbles is darkened	-2 In all other cases	28
3	Comprehension	4	+3 If only the bubble corresponding to the correct option is darkened	—	0 In all other cases	—	12